

ENVIRONMENTAL PRODUCT DECLARATION

RAINPLUS®



PRODUCT NAMES:	Rainplus®
SITE PLANTS:	Vestone/Vobarno
PROGRAM OPERATOR	EPDItaly
PUBLISHER	EPDItaly
DECLARATION NUMBER	2023WASTEHDPE0407
REGISTRATION NUMBER	EPDITALY0407
ISSUE DATE	18/04/2023
VALID TO	18/04/2028

in compliance with ISO 14025 and EN 15804:2012+A2:2019.

MADE IN ITALY



valsir®
QUALITY FOR PLUMBING

GENERAL INFORMATION

EPD OWNER:

Valsir S.p.A., Località Merlaro, 2 25078 Vestone (BS)

**PLANT INVOLVED
IN THE DECLARATION:**



Vestone: Località Merlaro, 2 25078 Vestone (Brescia)



Vobarno: Via della Ferriera, 1 25079 Vobarno (Brescia)

SCOPE OF APPLICATION:

This Environmental Product Declaration (EPD) is valid for Rainplus® product system. The production facilities are in Vestone and Vobarno (BS). The type of declaration is related to an average product produced partly in Vestone and Vobarno. The life cycle assessment is representative for the product introduced in the declaration for the given system boundaries.

PROGRAM OPERATOR:

EPDIItaly, via Gaetano De Castillia 10, 20124 Milano, Italia.

This declaration has been developed referring to EPDIItaly, following the General Programme Instruction; further information and the document itself are available at: www.epditaly.it. EPD document valid within the following geographical area: Italy and other countries according to sales market conditions.

CEN standard EN 15804 served as the core PCR (PCR ICMQ-001/15 rev.3). PCR review was conducted by Daniele Pace.

Contact via info@epditaly.it

INDEPENDENT CHECK:

Independent verification of the declaration and data, according to EN ISO 14025:2010.

Third party verifier: ICMQ SpA, via De Castillia, 10 20124 Milano (www.icmq.it)

EPD process certification (Internal)

EPD verification (External)

Accredited by: Accredia

CPC CODE:

3632 - Tubes, pipes and hoses, and fittings therefor, of plastics

CORPORATE CONTACT:

valsir@valsir.it

TECHNICAL SUPPORT:

Sphera <https://www.sphera.com>



COMPARABILITY:

Environmental statements published within the same product category, but from different programs, may not be comparable. In particular, EPDs of construction products may not be comparable if they do not comply with EN 15804.

ACCOUNTABILITY:

Valsir S.p.A. relieves EPDIItaly from any non-compliance with environmental legislation. The holder of the declaration will be responsible for the information and supporting evidence; EPDIItaly declines all responsibility for the manufacturer's information, data and results of the life cycle assessment.

REFERENCE DOCUMENT:

This declaration has been developed following the General Programme Instruction document of EPDIItaly, available at www.epditaly.it.

PRODUCT CATEGORY RULES (PCR):

PCR ICMQ-001/15 rev.3
EN 15804+A2 is the framework reference for PCRs.

COMPANY

COMPANY

Valsir was founded in 1987, on the basis of a precise industrial strategy adopted by the Silmar Group - a holding that is leader in the plumbing and heating market with a sales turnover of over 900 million Euro and 2,600 employees - with factories in Italy, in Valle Sabbia to the north of Brescia and abroad in Portugal, Poland, Russia, Romania, the Ukraine, France and South Africa.

Valsir is today a solid and expanding firm within a group whose true points of cohesion and strength lie within a strong sense of collaboration and the contribution of specific professional skills of each single component.

VALSIR - HEADQUARTERS

Location: Vestone (BS)



VALSIR - VOBARNO PRODUCTION PLANT

Location: Vobarno (BS)



VALSIR RECYCLING - CARPENEDA 1 PRODUCTION PLANT

Location: Carpeneda, Vobarno (Brescia)



VALSIR - CARPENEDA 2 PRODUCTION PLANT

Location: Carpeneda, Vobarno (Brescia)



MISSION

Our mission is to excel in the creation of innovative, environmentally sustainable and quality solutions by guaranteeing a meticulous and prompt service. Boasting deep roots within our territory and a strong commitment to internationalization, we adopt processes that are respectful of both people and the environment.

THE NUMBERS OF VALSIR (2021)

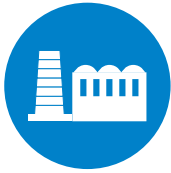

261,696 m²

total surface of which 117,334 m²
indoors



585 Employees



197,393,953 €

turnover



15,751,488 €

investments

25 patents

227 type approvals

28 product lines

7,000 items

MANAGEMENT SYSTEM AND CERTIFICATIONS



ISO 9001:2015

Quality management system
(In force since 2001)



ISO 50001:2018

Energy management system
(In force since 2017)



ISO 14001:2015

Environmental management
systems
(In force since 2018 for the plant
in Vestone)

COMPANY AWARDS

Excellence of the year for Innovation
and Leadership - Best Job 2019

Singapore Green Building



GOAL AND SCOPE OF EPD

The entire life cycle of the product is considered (Type of EPD: cradle to grave) and the modules described below are declared in this EPD:





- Modules **A1-A3** include those processes that provide energy and material input for the system (A1), transport up to the factory gate of the plant (A2), manufacturing processes, packaging materials as well as waste processing and emissions to air from molding and extrusion processes (A3).
- Module **A4** includes the transport from the production site to the customer or to the point of installation of the products.
- Module **A5** considers all piping systems installation steps (like screws, cement, oil use and water consumption) also packaging waste processing (recycling, incineration, disposal). Credits from energy substitution are declared in module D. During this phase an overlap of 2% has been considered.
- Module **B1** considers the use of the installed product. During the use of plastic piping systems, a scenario of zero impact is considered.
- Module **B2** includes the maintenance of the product. A scenario of zero impact is considered.
- Modules **B3-B4-B5** are related to the repair, replacement and refurbishment of the products. If the products are properly installed no repair, replacement or refurbishment processes are necessary. A scenario of zero impact is then considered.
- Modules **B6-B7** consider energy use and operational water to operate building integrated technical systems. No operational energy or water use are considered. A scenario of zero impact is then considered.
- Module **C1** considers deconstruction, including dismantling or demolition of the product from the building site. The energy consumption related to such activities is considered.
- Module **C2** considers transportation of the discarded piping system to a recycling or disposal process.
- Module **C3** considers waste processing for products recycling and incineration.
- Module **C4** includes all waste disposal processes, including pre-treatment and management of the disposal site.
- Module **D** includes benefits from all net flows in the end-of-life stage that leave the product boundary system after having passed the end-of-waste stage. Benefits from packaging incineration (electricity and thermal energy) are declared within module D.

The type of EPD is “cradle to grave” and it is an average EPD for the product Rainplus® produced in Valsir S.p.A. plants located in Vobarno (BS) and Vestone (BS) and sold worldwide. All data refer to the 2019 production and sales.

According to the PCR ICMQ-001/15 rev.3 the LCA study and the relative EPD, is “cradle to grave”. Modules included are A1, A2, A3, A4, A5, B, C and D. All manufacturing activities and packaging/auxiliary's production are in module A3, while energy production and input materials are in A1. Transport to clients (A4) and installation (A5) are included together with end of life scenarios (benefits and loads included according to D module).

The declaration is 1b (average product from more than one plant of a specific manufacturer).

The production facilities are in Vobarno (IT) and Vestone (IT). The market range is Worldwide.

 PRODUCT STAGE			 CONSTRUCTION PROCESS STAGE		 USE STAGE							 END OF LIFE STAGE				 BENEFITS AND LOADS BEYOND THE SYSTEM BOUNDARIES
Raw material supply	Transport	Manufacturing	Transport from the gate to the site	Assembly	Use	Maintenance	Repair	Replacement	Refurbishment	Operational energy use	Operational water use	De-construction demolition	Transport	Waste processing	Disposal	Reuse- Recovery- Recycling- potential
A1	A2	A3	A4	A5	B1	B2	B3	B4	B5	B6	B7	C1	C2	C3	C4	D
√	√	√	√	√	√	√	√	√	√	√	√	√	√	√	√	√

√ = modules included in the study.

Geographical validity: Worldwide

Database: GaBi Database 2021.1

Software: EPD Process Creator, implemented through GaBi professional 10 and GaBi Envision 9.0 software. The identification code of the EPD process tool used is: Valsir LCA tool - Drainage and waste piping system V.3 [10/04/2023 - DB Version 2022.2] developed by sphera.

EPD realized by means of a validated algorithm:

In 2021 Valsir S.p.A. implemented and certified a Process for EPD generation by using an algorithm that has been validated and certified by ICMQ S.p.A., in agreement with EPDIItaly's requirements. The process is based on an automatic data collection from different manufacturing plants that have been integrated, verified and validated in compliance with internal procedures. The validated algorithm allows the automatic calculation of the indicators reported into the current EPD coming from an LCA model implemented into the EPD process tool.

PRODUCTS DESCRIPTION

1. RAINPLUS® DRAINAGE SYSTEM

Rainplus® is the Valsir siphonic system used for the drainage of rainwater from medium and large sized roofs. Through its special operation, this system is capable of discharging large flows of water at high flow speed, keeping the size of pipes reduced thanks to the possibility of using their full cross section. For this reason, Rainplus® is the most suitable system to respond to the increasing levels of rainfall experienced in recent years.

The heart of the system is made up of special roof outlets designed and tested in accordance with ASME A112.6.9 and EN 1253-2 standards; these outlets prevent air from entering inside them and, consequently, inside the Valsir HDPE high density polyethylene pipes to which they are connected. In this way, positive and negative pressures are generated in the system and allow it to move water without the need for slopes, therefore with perfectly horizontal pipes that reduce possible interferences with other technological systems or structural parts of the building. This allows getting as close as possible to water delivery points, making it possible to easily implement the most current strategies of recovery and reuse of rainwater according to a design approach aimed at environmental sustainability.

The advantages offered by this technology are numerous; among them a significant cost containment thanks to the reduction of the material used and of the installation time, as well as an increase in the efficiency of the entire drainage system.

Figure Rainplus range.



Technical data

Table Rainplus® 110 outlet technical data.

Property	Value
Connection type	Vertical
Connection outer diameter	110 mm
Outlet body diameter	286 mm
Maximum flow rate	65 l/s
Leaf guard material	PP (polypropylene) + additive for UV resistance
Maximum load on leaf guard	200 kg
Anti-vortex plate material	Aluminium painted with blue epoxy paint
Flange material	Aluminium painted with blue epoxy paint
Outlet body material	Aluminium painted with blue epoxy paint
Connection socket material	HDPE (high density polyethylene)
Safety clip material	Stainless steel painted with red epoxy paint
O-ring material	EPDM (2 O-rings)
Material of outlet fastening screws	Stainless steel AISI 304
Protection cap material	Yellow PP (polypropylene)
Standards	ASME A112.6.9 DIN EN 1253

Table Rainplus-S clips technical data.

Property	Value	Test method
Clip material	Steel for cold-molding DX51D	EN 10346
Screw material	Steel Class 4.8	EN 898-1:2009
Galvanization	Cold electro-galvanization 6÷9 µm	UNI ISO 2081:2009

Table Technical data of M10, G1/2" and G1" clips.

Property	Value	Test method
Clip material	Steel for cold-molding DD11	EN 10111
Nut material	Steel Class 8	EN 898-2:2012
Screw material	Steel Class 4.8	EN 898-1:2009
Galvanization	Cold electro-galvanization 6÷9 µm	UNI ISO 2081:2009

Table HDPE technical data

Property	Value	Test method
Pipe material	High density polyethylene PE 80	-
Fitting material	High density polyethylene PE 80	-
Seal material ⁽¹⁾	SBR	-
Colour	Black	-
Diameters	32÷315 mm	-
Application	High and low temperature waste and drainage systems inside the building, externally anchored to the walls of the building (application area B) or buried in ground within the building structure (application area D) or for both installations (application area BD); ventilation for waste systems; both gravity and under negative pressure rainwater drainage systems.	-
Connections	Butt welding, welding using electrofusion coupling, push-fit method with rubber seal, mechanical joint with flange, mechanical joint with screw fitting.	-
Minimum operating temperature ⁽²⁾	-40°C	-
Maximum temperature of waste water	+95°C (intermittent) +80°C (continuous)	-
Minimum pressure ⁽³⁾	-800 mbar (SDR 26) -450 mbar (SDR 33)	-
Maximum pressure ⁽⁴⁾	Without push-fit sockets or expansion sockets: +5 bar (SDR 26); +4 bar (SDR 33) With push-fit sockets or expansion sockets: +0.5 bar	-
Composition of waste water	pH 0÷14	-
Density at 23°C	> 945 kg/m ³	UNI EN ISO 1183-2
Elasticity modulus	1000 MPa	ISO 527-2
Tensile strength	22 MPa	ISO 527-2
Ultimate elongation	≥ 350%	ISO 625-3
Carbon black content	2.0-2.5%	S14476-1
Thermal stability (OIT) at 200°C	≥ 20 min	EN 728
Crystalline melting temperature	≥ 130°C	ISO 11357-3
Linear heat expansion coefficient	0.20 mm/m·K	-
UV resistance	Suitable for storage outdoors as well as applications with exposure to sunlight	-
Halogen content	Halogen-free	-
Fire resistance	Class M4 Class B2 Euroclass E	NF P 92-505 DIN 4102-1 EN 13501-1
Reference construction standard	EN 1519-1 - AS/NZS 5065 - AS/NZS 4401 - SN S92010 SN S92012 - DIN 19537-2 - DIN 19535-10 - NBK 8 SI 4479-1 - SANS 8770	-
Packaging	Pipes in wooden frames with strapping Fittings in cardboard boxes	-

(1) Seal present on some fittings only. For most fittings, jointing is made by welding.

(2) For joint realization with both butt-welding and electrofusion coupling, the minimum permitted temperature is -5°C.

(3) Operating conditions at 20°C valid only for rainwater drainage systems under negative pressure (Rainplus® siphonic drainage systems).

(4) Maximum pressures in relation to special applications not in compliance with EN 1519 considering a safety factor SF=1.25 and temperature of 20°C.

2. DESCRIPTION OF DRAINAGE SYSTEM COMPONENTS

The environmental burdens are calculated in relation to the functional unit, which resulted for a rainwater drainage system in a building. The functional unit represents 5200 m² of a typical industrial production plant.

The EPD is declared as the average environmental performance for Valsir Rainplus® families of siphonic rainwater system, starting from the outlets on the roof surface, passing through the piping and fixing system which are needed to collect the roof outlets to the system end point outside of the building.

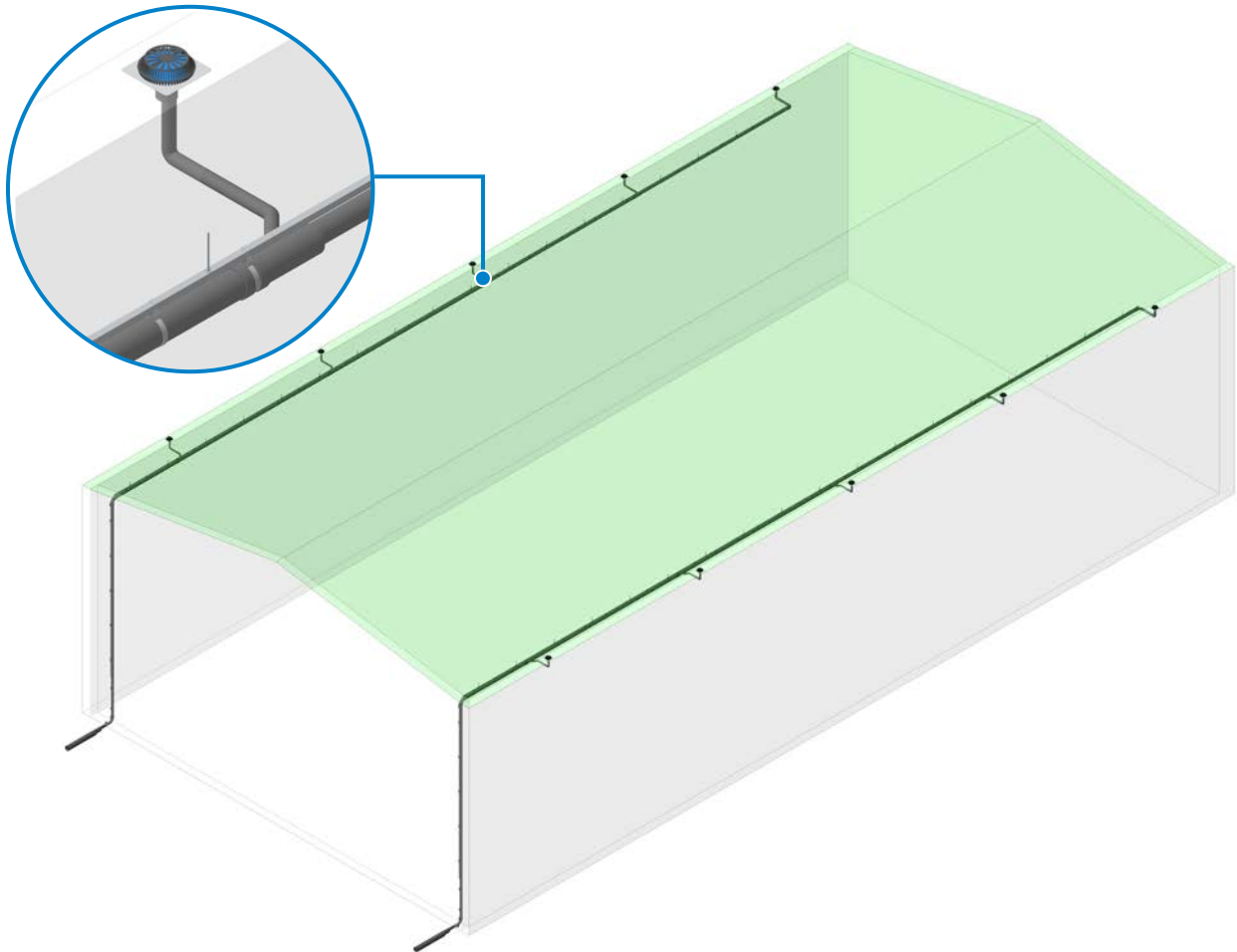

3. PRODUCTS DISTRIBUTION

Pipes, fittings and Rainplus® components are supplied to customers in customized dimensions with appropriate protection and packaging. The product packaging is made of wooden pallet and PET stripes for the pipe, and PE film, cardboard, labels, PP tape, PET stripes and wooden pallets for the fittings and Rainplus® components.



4. BASE MATERIAL AND ANCILLARY MATERIALS

Material	Rainplus pipe	Rainplus fitting
Additives and pigments	0%	0.1%
Alluminium	-	5.5%
Barium sulphate	0%	0%
EPDM	-	0.3%
Natural rubber / HNBR	-	0%
Polyamide	-	0%
Polyethylene [HDPE]	100%	76.6%
Polypropylene	0%	1.7%
Polypropylene [internally re-granulated]	-	3.1%
SBR	0%	0.9%
Stainless steel/galvanized steel	-	11.8%
Zinc stearate		0%
Wires	-	0%
Total	100%	100%

Service Conditions - Application classes as per EN ISO 15874 and ISO 10508.
Technical properties.

5. INSTALLATION

Water, fast fixing cement, wall fixing metals, silicon and electricity are used during installation. No emissions are generated during installation and piping systems installations do not cause health or environmental hazards.

- **Functional unit**

The functional unit is defined as “The collection and withdrawal of rainwater from a typical flatroof of a 5200 m² standard industrial production plant. The rainfall drainage system consists of the Rainplus® families of siphonic rainwater system, starting from the outlets on the roof surface, passing through the piping and fixing system which are needed to collect the roof outlets to the system end point outside of the building with a service life time of 50 years (aligned with the life time of the building).

Name	Value	Unit
Reference flow	534.79	Kg/FU
Extruded Pipes	491.18	Kg/FU
Molded components	23.06	Kg/FU
Metal components/gaskets	10.08	Kg/FU
Plastic components/gaskets	10.46	Kg/FU
Conversion factor to 1 kg	0.00187	
Conversion factor to 1 m	0.0053	
Total pipes length	190	m
Number of fittings	145	pcs
Number of Rainplus® components	432	pcs

Dangerous materials: The product does not contain any substances included in the “Candidate List of Substances of Very High Concern for Authorization” compliant with /REACH/ and with EC 1272/2008.

The total mass involved is 534.79 kg of which 491.18 kg of extruded plastic pipes, 23.06 kg of plastic components internally molded and 20.54 kg of plastic/metal inserts manufactured by an external supplier.

- **Condition of use**

Operational use (pumping energy) is not relevant for the EPD, since it falls outside the system boundaries of the LCA project. Maintenance is not needed for the Rainplus® system; a general scenario of zero impact for the system is considered.

- **Reference service life**

Plastic piping systems are regarded as having 50 years RSL independent of their material according to /PREN 16904:2021/. We assume the same as the other components being part of the drainage system.





- **End of life**

After the demolition and deconstruction phase, piping and drainage systems can be incinerated, sent to landfill or recycled.

LCA RESULTS

The tables below show the results of the Rainplus® LCA (Life Cycle Assessment). Additional environmental impact indicators are not declared according to /EN 15804 + A2/ chapter 7.2.3.2.

Table Environmental impact per functional unit





Parameter - Unit											
	A1	A2	A3	A4	A5	B1-B7	C1	C2	C3	C4	D
GWP total [kg CO ₂ -eq.]	1.20E03	8.41E00	-3.80E01	4.74E01	1.95E03	0	6.14E00	9.29E01	2.94E02	0	-8.86E02
GWP fossil [kg CO ₂ -eq.]	1.20E03	8.14E00	3.77E01	4.73E01	1.52E03	0	6.13E00	9.28E01	2.92E02	0	-8.82E02
GWP biogenic [kg CO ₂ -eq.]	4.88E00	2.69E-01	-7.58E01	6.29E-02	4.21E02	0	3.62E-03	1.27E-01	1.63E00	0	-3.89E00
GWP luluc [kg CO ₂ -eq.]	8.15E-02	3.68E-04	3.77E-02	1.75E-03	5.52E-01	0	3.98E-04	4.07E-03	1.96E-02	0	-6.58E-02
ODP [kg CFC-11-eq.]	6.96E-09	8.31E-13	4.83E-10	4.27E-12	7.50E-09	0	6.06E-11	9.18E-12	1.13E-09	0	-9.60E-10
AP [mole of H ⁺ -eq.]	2.22E00	8.33E-03	6.79E-02	4.16E-01	1.04E01	0	9.01E-03	8.19E-02	2.22E-01	0	-1.83E00
EP - freshwater [kg P eq.]	1.16E-03	1.89E-06	9.45E-04	1.07E-05	1.03E-02	0	2.75E-06	2.09E-05	1.24E-03	0	-8.83E-04
EP - marine [kg N eq.]	5.87E-01	2.84E-03	3.11E-02	1.08E-01	1.12E00	0	2.46E-03	2.55E-02	6.19E-02	0	-4.70E-01
EP - terrestrial [mole of N eq.]	6.29E00	3.15E-02	3.12E-01	1.19E00	1.17E01	0	2.63E-02	2.88E-01	6.54E-01	0	-5.04E00
POCP [kg NMVOC eq.]	2.68E00	7.97E-03	8.02E-02	3.05E-01	3.47E00	0	6.95E-03	7.64E-02	1.61E-01	0	-2.21E00
ADPF* [MJ]	4.14E04	1.13E02	2.41E02	6.25E02	1.92E04	0	1.30E02	1.25E03	2.21E03	0	-3.29E04
ADPE* [kg Sb eq.]	3.31E-04	4.25E-07	1.80E-05	2.26E-06	5.77E-02	0	7.29E-07	4.69E-06	2.35E-05	0	-1.24E-04
WDP* [m ³ world eq.]	2.11E02	2.19E-02	2.92E01	1.15E-01	2.66E02	0	4.58E-01	2.42E-01	3.38E01	0	-1.58E02

* The results of this environmental impact indicator should be used with caution because uncertainties about these results are high or because the experience of the indicator is limited.

- GWP** Global warming potential
- ODP** Depletion potential of the stratospheric ozone layer
- AP** Acidification potential of land and water
- EP** Eutrophication potential
- POCP** Formation potential of tropospheric ozone photochemical oxidants
- ADPE** Abiotic depletion potential for non fossil resources
- ADPF** Abiotic depletion potential for fossil resources
- WDP** Water (user) deprivation potential, deprivation-weighted water consumption

LCA RESULTS

Table Resource use per functional unit





Parameter - Unit											
	A1	A2	A3	A4	A5	B1-B7	C1	C2	C3	C4	D
PERE [MJ]	2.40E03	6.86E-01	-1.38E02	3.53E00	4.39E03	0	1.88E01	7.58E00	7.73E02	0	-8.27E02
PERM [MJ]	0	0	8.11E02	0	-9.37E01	0	0	0	0	0	0
PERT [MJ]	2.40E03	6.86E-01	6.73E02	3.53E00	4.30E03	0	1.88E01	7.58E00	7.73E02	0	-8.27E02
PENRE [MJ]	1.83E04	1.14E02	2.36E02	6.28E02	1.92E04	0	1.30E02	1.26E03	2.21E03	0	-3.29E04
PENRM [MJ]	2.31E04	0	5.46E00	0	5.67E00	0	0	0	0	0	0
PENRT [MJ]	4.14E04	1.14E02	2.42E02	6.28E02	1.92E04	0	1.30E02	1.26E03	2.21E03	0	-3.29E04
SM [kg]	9.04E-01	0	1.48E01	0	3.09E02	0	0	0	0	0	0
RSF* [MJ]	0	0	0	0	0	0	0	0	0	0	0
NRSF* [MJ]	0	0	0	0	0	0	0	0	0	0	0
FW [m³]	5.80E00	9.32E-04	7.03E-01	4.88E-03	7.66E00	0	2.85E-02	1.03E-02	1.12E00	0	-4.33E00

* Reference to only foreground system.





- PERE** Use of renewable primary energy as energy carrier
- PERM** Use of renewable primary energy as raw materials
- PERT** Total use of renewable primary energy resources
- PENRE** Use of non-renewable primary energy as energy carrier
- PENRM** Use of non-renewable primary energy as raw materials
- PENRT** Total use of non-renewable primary energy resources
- SM** Use of secondary material
- RSF** Use of renewable secondary fuels
- NRSF** Use of non-renewable secondary fuels
- FW** Use of net fresh water

LCA RESULTS

Table Output flows and waste categories per functional unit

											
Parameter - Unit	A1	A2	A3	A4	A5	B1-B7	C1	C2	C3	C4	D
HWD [Kg]	2.59E-06	3.93E-10	7.69E-07	2.24E-09	1.29E-06	0	9.30E-09	4.34E-09	2.66E-07	0	-1.54E-06
NHWD [Kg]	1.93E01	1.16E-02	4.49E00	6.31E-02	5.13E02	0	2.76E-02	1.28E-01	1.87E01	0	-1.53E01
RWD [Kg]	4.74E-01	1.88E-04	1.11E-02	9.73E-04	5.13E-01	0	2.16E-02	2.07E-03	2.19E-01	0	-2.42E-01
CRU [Kg]	0	0	0	0	0	0	0	0	0	0	0
MFR [Kg]	0	0	0	0	1.50E01	0	0	0	4.61E02	0	0
MER [Kg]	0	0	0	0	0	0	0	0	0	0	0
EEE [MJ]	0	0	0	0	2.98E01	0	0	0	0	0	0
EET [MJ]	0	0	0	0	2.65E01	0	0	0	0	0	0

- HWD** Hazardous waste disposed
- NHWD** Non-hazardous waste disposed
- RWD** Radioactive waste disposed
- CRU** Components for re-use
- MFR** Materials for recycling
- MER** Materials for energy recovery
- EEE** Exported electrical energy
- EET** Exported thermal energy

											
Parameter - Unit	A1	A2	A3	A4	A5	B1-B7	C1	C2	C3	C4	D
Biog. C in packaging [Kg]	0	0	1.8E+001	0	0	0	0	0	0	0	0
Biog. C in product [Kg]	0	0	0	0	0	0	0	0	0	0	0

- Biog. C in packaging** Biogenic carbon content in packaging
- Biog. C in product** Biogenic carbon content in product

CALCULATION RULES

ASSUMPTIONS

Where possible, a conservative approach has been adopted, overestimating burdens to prove irrelevance. In other cases, alternatives data were selected based on scientific experience in order to improve the accuracy of the model. Where it was not possible to know the precise composition of materials in the supply chain (due to commercial or industrial confidential suppliers' reasons or due to missing datasets), these have been approximated with LCIs of similar materials, estimated by the combination of available dataset or reconstructed with literature data.

- Lead batteries have been taken into account as a conservative choice for batteries used in forklift.
- For brass recycling the steel billet recycling process has been used as conservative choice (melting temperature for recycling brass is lower than for steel).
- Where potential benefits from energy recovery in A5 and C modules are considered, for rest of world countries (other than Europe) these are calculated based on the European grid mix.
- For boilers (natural gas fed) an efficiency factor equal to 0.95 is considered.
- The functional unit is defined without packaging.
- In case of transports on truck where the payload was neither available nor conceivable, utilization factor of 0.61 has been considered (empty way back).
- For masterbatches/pigments whose exact composition was not available, a 95% of main polymer has been considered in addition to 5% pigment and in case of recycling, only the avoided burden of the polymer is considered (avoided burden of the pigment is neglected as conservative choice).
- For millings used to mill plastic scraps from internal manufacturing activities whose specific consumption was not available, an average between Bivite's and Govoni's milling consumption has been taken.
- For metal components end of life, a 60% recycling percentage has been considered based on /ISPRA/ reference, 40% is sent to landfill.
- For distribution the distance between Valsir warehouse and the country capital is considered and an estimated additional distance of 500 km by truck is added to the transport via ship.
- Distance to disposal site after demolition is assumed to be 100 km.
- For end of life scenarios, as Building&Construction (ISPRA) update percentage for Italy did only consider the overall recovery percentage, not distinguishing between recycling and energy recovery, the relative proportion has been assumed to be the same as in /PLASTIC EUROPE (2010)/ containing specific information for 2010.
- For plastic systems installation scrap production an average product has been considered, taking into account a worst case approach not including the related packaging.
- Whenever transport distances were not available (i.e. C2 module) a general 100 km has been considered.
- As CHP plant has been only partially in use in 2019, the electricity amount produced by the plant has been considered as taken from grid, as conservative choice.
- As different type of pigments were involved, a generic pigment polymer-based has been considered (95% PP + 5% average pigment).

CUT-OFF RULES

In the assessment, all available data from production process are considered, i.e. all raw materials used, utilised thermal energy, and electric power consumption using best available LCI datasets. Thus material and energy flows contributing less than 1% of mass or energy are considered.

Production of capital equipment, facilities and infrastructure required for manufacture are outside the scope of this assessment.

The sum of the excluded material flows does not exceed 5% of mass, energy or environmental relevance.

DATA QUALITY

The data quality can be considered as good. The LCA models have been checked and most relevant flows were considered. Technological, geographical and temporal representativeness is appropriate.

EXAMINATION PERIOD

Primary data collected in the context of this study refer to 2019.

ALLOCATION - UPSTREAM DATA

Information about single datasets is documented in <http://database-documentation.gabi-software.com/support/gabi/>.

SCENARIOS AND ADDITIONAL TECHNICAL INFORMATION

- Module **A1** refers to all raw materials impacts production with packaging included and all types of energy inputs
- Module **A2** includes the raw materials (also auxiliary's and packaging) transport to the factory gate
- Module **A3** comprises all production activities and waste treatment and process emissions (both to air and to water). Such activities refer to Valsir direct activities. Primary data have been used for plastic extrusion for waste pipes production and plastic injection moulding for PP fittings production.
- Module **A4** takes into account the transport to the final customer/distributor. In 2019, Rainplus® system distribution scenario is shown in the table below. What is not sold neither to Europe nor to Italy, is sent to the rest of the world.

GaBi transport dataset

Product	IT	EU	Truck [km]	Ship [km]
			Truck-trailer, Euro 6, up to 28 t gross weight/12.4t payload capacity	Average ship, 27500 dwt payload capacity/ocean going
Pipes	27.51%	44.7%	810.41	1427.1
Fittings/Rainplus®	13.2%	41.47%	121.76	141.39

- For Module **A5** the following parameters have been taken into account:

Installation

Material	Rainplus®
Scrap percentage [%]	2
Water [kg]	1
Silicon [kg]	0.243
Fast fixing cement [kg]	0.348
Wall fixing metals [kg]	402.927
Electrical energy [kWh]	6.753
Water for cement [kg]	0.149

Moreover, following leftover end of life scenarios have been included:

	Landfill	Incineration	Mechanical recycling	Source
Leftover	0%	%	100%	Assumption
Distance to treatment	100 km	100 km	100 km	Assumption

- Module **B** (maintenance and operational use): Operational use and Maintenance are not relevant for the piping system. According to /FprEN 16904/ a general scenario of zero impact for plastic piping systems inside the building is considered for all B modules (B1-B2-B3-B4-B5-B6-B7).

- Module **C1** (Deconstruction/demolition) has been included and deconstruction impacts have been considered.
- Module **C2, C3** (recycling and incineration with energy recovery) and **C4** (landfilling) consider the end of life scenarios of the product, considering all components of the piping system. The percentages to the given scenarios have been suggested by /FprEN 16904/ as shown below:

Material	EoL treatment -	Source	Distances to treatment [C2]
Piping systems	100% mechanical recycling	/PREN 16904:2021/	100 km
Metal components/fittings	100% recycling	/PREN 16904:2021/	100 km

- Module **D** consists of loads and benefits beyond the system boundaries.

OTHER ADDITIONAL ENVIRONMENTAL INFORMATION

EMISSIONS TO INDOOR AIR:

No direct emissions at the building site. Valsir S.p.A. confirms that the Rainplus® waste piping system does not contain any substances mentioned on the REACH SVHC -list.

EMISSIONS TO SOIL AND WATER:

No direct emissions at the building site. Valsir S.p.A. confirms that the Rainplus® waste piping system does not contain any substances mentioned on the REACH SVHC -list.

REFERENCES

CEN/TR 15941	Sustainability of construction works - Environmental product declarations - Methodology for selection and use of generic data; CEN/TR 15941:2010
CPR	Regulation (EU) No 305/2011 of the European parliament and of the council of 9 March 2011 laying down harmonised conditions for the marketing of construction products and repealing Council Directive 89/106/EEC
EN 15804+A2	EN 15804:2012+A2:2019: Sustainability of construction works -Environmental Product Declarations - Core rules for the product category of construction products
EN ISO 14025	EN ISO 14025:2011-10 Environmental labels and declarations - Type III environmental declarations - Principles and procedures
EN ISO 14040	EN ISO 14040:2009-11 Environmental management - Life cycle assessment - Principles and framework
EN ISO 14044	EN ISO 14044:2006-10 Environmental management - Life cycle assessment - Requirements and guidelines
GABI TS	GaBi ts dataset documentation for the software-system and databases, LBP, University of Stuttgart and Sphera, Leinfelden-Echterdingen, 2021 (http://documentation.gabi-software.com/)
GHG PROTOCOL	World Resource Institute, wbcscd, Product Life Cycle Accounting and Reporting Standard. September 2011; http://www.ghgprotocol.org/standards/product-standard
GUINÉE 2001	Guinée et al, An operational guide to the ISO-standards, Centre for Milieukunde (CML), Leiden, the Netherlands, 2001
PCR ICMQ 3.0	ICMQ-001/15, 2017– rev.3: Prodotti da costruzione e servizi per costruzioni, EPD Italy. Data di emissione: 02/12/2019, validità fino al: 01/12/2024.
REGOLAMENTO EPDITALY V.5.2	Regolamento del Programma EPDItaly. Data di emissione: 16/02/2022.
ISO 15686	ISO 15686:2011-05, Buildings and constructed assets - Service life planning
ISPRA	Rapporti rifiuti speciali, ISPRA 2020
PREN 16904:2021	Plastics piping systems - Environmental product declarations - Product Category rules complementary to EN 15804, for plastic piping systems inside buildings.
EUROSTAT	EUROSTAT Data browser: Packaging waste by waste management operations https://ec.europa.eu/eurostat/databrowser/view/ENV_WASPAC_custom_344983/default/table?lang=en https://www.corepla.it/
COREPLA	https://www.google.com/url?sa=t&rct=j&q=&esrc=s&source=web&cd=&ved=2ahUKEwi vqNya4vjvAhVLM6QKHWJ3BOQQFjAAegQIBhAD&url=https%3A%2F%2Fwww.corepla.it%2Fdocumenti%2F060bbd18-7fbf-4b76-b9b8-d28f4a973607%2FRELAZIONE%2BSULLA%2BGESTIONE%2B2019.pdf&usq=AOvVaw2LuwjziOZqFmldV20AvQz7
COMIECO	https://www.comieco.org/25deg-rapporto-annuale-comieco-sulla-raccolta-differenziata-di-carta-e-cartone-in-italia/
RILEGNO	http://www.rilegno.org/rapporto-2020/
PLASTIC EUROPE (2010)	Analysis of recovery of plastic waste in the building and construction sector (2010). Recovery and disposal of plastic B&C waste in EU27+2 and by country (2020).

**PLASTIC WASTE
FROM B&C
IN EU 2018**

Final report "Plastic waste from B&C in EU 2018" . Overview plastic waste from building & construction by polymer type and by recycling, energy recovery and disposal - Building & construction post consumer plastic waste generation EU 28+2 in 2018 (kt), Plastic Europe 2018

REACH

The Candidate List of Substances of Very High Concern (SVHC). Pursuant to Article 59(10) of the REACH Regulation (EC) No 1907/2006. <https://echa.europa.eu/it/candidate-list-table>

Lined writing area with horizontal lines and a vertical column of icons on the right side.



Lined writing area with horizontal lines and a vertical column of blue icons on the right side. The icons include symbols for a balance scale, a person, a flame, a water drop, a crescent moon, a swirl, a hand, a gear, a triangle, a vertical bar, and a curved arrow.



WASTE SYSTEMS



SUPPLY SYSTEMS



GAS SYSTEMS



FLUSHING SYSTEMS



BATHROOM SYSTEMS



TRAPS



RADIANT SYSTEMS



DRAINAGE SYSTEMS



HRV SYSTEM



ACADEMY



SEWER SYSTEMS



WATER TREATMENT



valsir[®]
QUALITY FOR PLUMBING

VALSIR S.p.A. - Società a Socio Unico
Località Merlaro, 2
25078 Vestone (BS) - Italy
Tel. +39 0365 877.011
Fax +39 0365 81.268
e-mail: valsir@valsir.it
www.valsir.it

Soggetta all'attività di direzione e coordinamento ex art. 2497 bis C.C.
da parte di Silmar Group S.p.A. - Codice Fiscale 02075160172